



Grafisk Maskinfabrik

# SU3, GR80 and GR80K

Wast removal unit and Trim shredders



SU3



GR80K



GR80

SU3, GR80 and GR80K

# SU3, GR80 and GR80K

## Description:

### GR80:

The GR80 trim shredder was especially designed for use with printing presses or slitters already provided with waste removal equipment. It can efficiently shred a wide range of label materials and reduce them to a few percentage of the original volume. The GR80 trim shredder is mounted in a stand the height of which is adjustable up to max. 110 cm (~43.3in) above the floor.

### SU3:

The SU3 Waste Removal Unit was designed to convey trim from slitters of almost any make to a waste bin. The SU3 is mounted on wheels and can easily be moved from one machine to another if required. The standard equipment comprises a noiseless ventilator enclosed in a noise absorbing cabinet. Height adjustment of the suction nozzle ranges from 1.0-1.5 m, (~3-5 ft) and the maximum distance from the suction nozzle to the trim knives is 0.25 – 0.5 m (~9.8 - 19.7in), subject to the material and thickness.

### GR80K COMBI:

The GR80K COMBI is a trim shredder combined with a built-in waste removal unit. The combi shredder has connections for two machines.

## Technical specifications:

Model	GR80	SU3	GR80K
Max. trim width [mm]	30	20	30
Max. trim extraction speed [m/min]	200	150-200	250
Connection tube diameter inlet int./ext. dimensions [mm]	63/75	--	2*56/ 2*63
Connection tube diameter outlet [mm]	--	--	90

## Dimensions:

Model	GR80	SU3	GR80K
(LxBxH) [mm]	600x480x1100	600x400x600	650x650x860
weight [kg]	45	35	100
power supply	3 x 230/400 V AC, 50/60 Hz	3 x 230/400 V AC, 50/60 Hz	3 x 230/400 V AC, 50/60 Hz

## Optional equipment for GR80 and GR80K COMBI:

- Lubrication system for use for materials with adhesive in order to prevent the adhesive from building up on the cutters.

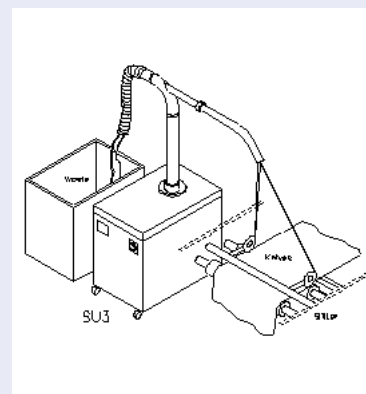

SU3 sketched in use.



Shredded paper.

## Grafisk Maskinfabrik A/S

Bregnerødvej 92 DK-3460 Birkerød, Denmark  
Phone: +45 45 81 23 00 Fax: +45 45 81 99 56  
Website: www.gm.dk e-mail: gm@gm.dk

